

The 28' Carousel

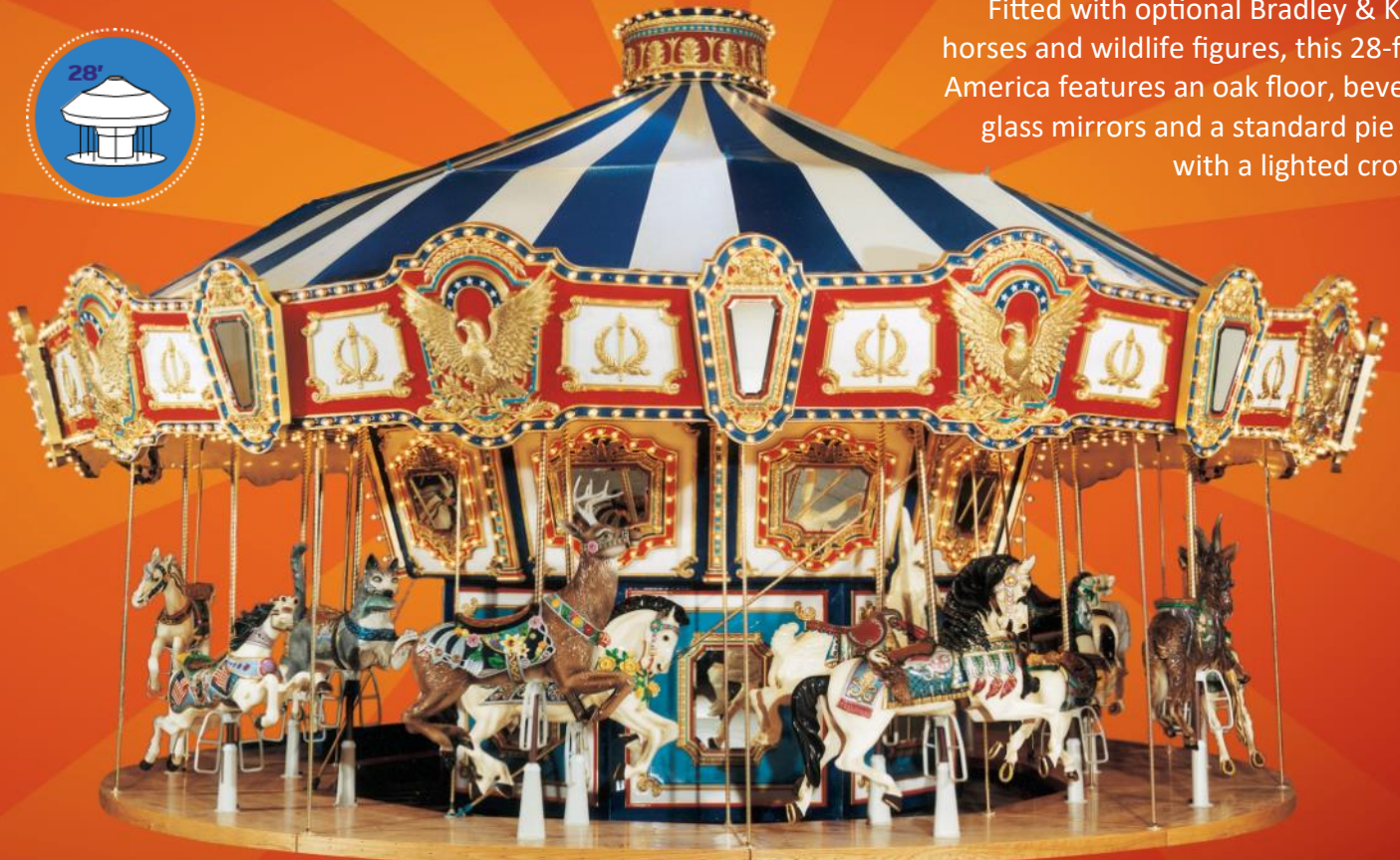

Fitted with optional Bradley & Kaye horses and wildlife figures, this 28-foot America features an oak floor, beveled glass mirrors and a standard pie top with a lighted crown.



Designed for maximum capacity in minimal space, the Chance Rides 28-foot carousel is meticulously fashioned with old-world craftsmanship.



- Americana
- Victorian



316.945.6555

sales@chancerides.com

Chancerides.com

The 28' Carousel

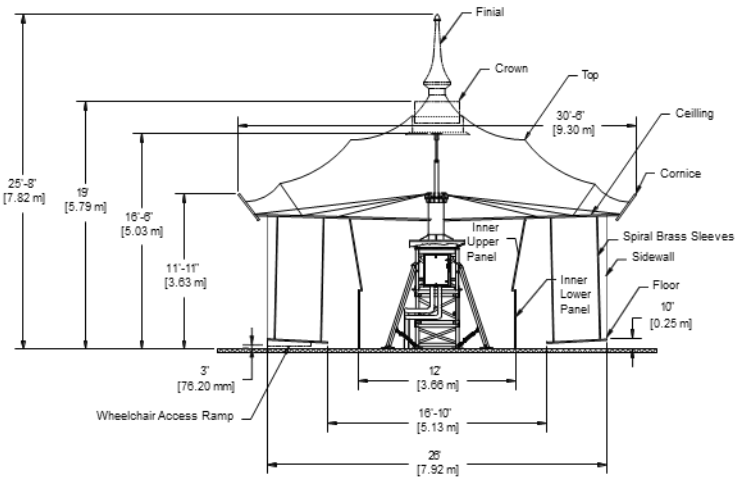
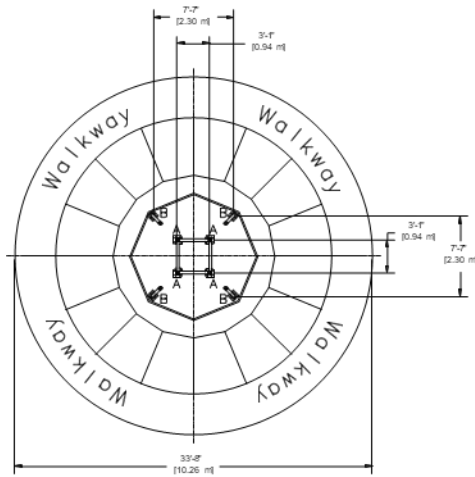

FEATURES

STANDARD FEATURES

- 18 Fantasy horses, 1 Columbia or Goddess of Cherubs chariots
- Americana or Victorian Scenery
- Ribbon or Pie top
- Simulated wood, color coordinating non-slip or aluminum tread plate floors
- Spiral brass sleeves on horse poles and floor hanger rods
- Maintenance-free, greaseless Nylatron® bearings
- Electric, variable-speed drive
- Lap belts
- Operator pedestal

OPTIONAL FEATURES

- 20 Carousel figures with no chariot or 16 carousel figures with 2 chariots
- Hand-crafted Bradley & Kaye horses and wildlife figures by Chance Rides
- Spinning Tub or Swan Chariot
- Wheelchair accessible chariot
- Lighted ribbon or Americana top
- Lighted finial or crown
- Polygon® permanent roof

- Antique-style lighted Americana or Victorian ceiling
- Beveled glass mirrors for scenery panels
- Online factory diagnostics package
- Remote Access
- Side walls
- Custom theming and figures

SPECIFICATIONS

SEATING

Number of seats.....standard 18 horses (2 abreast) and
1 chariot

Maximum number of passengers per seat:

Horses.....1 adult or 1 child

Chariot.....2 adults or 3 children

Average passenger weight per seat:

Horses.....170 lbs. (77 kg)

Chariot.....340 lbs. (154 kg)

Maximum total number of passengers*.....20 adults
and 18 children

Maximum total passenger weight.....5,020 lbs. (2,277 kg)

Minimum passenger height.....42 in. (107 cm)
(unaccompanied by adult)

Loading.....all passengers simultaneously

Maximum unbalance.....6 adults (1,020 lbs./463 kg)

PERFORMANCE

Direction of travelcounterclockwise

Max. Ride speed......5 rpm

Ride duration (maximum)......2.5 min.

Ride duration (recommended)......2 min.

Maximum wind speed (operating)......35 mph

Maximum wind speed (static)......60 mph

MAXIMUM RIDE WEIGHT (EMPTY)

With aluminum floors.....14,500 lbs. (6,577 kg)

Drive.....variable speed electric

POWER REQUIREMENTS**

Drive.....4.3 kW

Lights.....2.0 kW

Control Circuit.....3.7 kW

Total.....10.0 kW

Min./Max. voltage208/230 volt, 3 phase, 60Hz

DRIVE**

Type.....variable speed electric

Number of motors.....1

Horsepower Rating......5

LIGHTING**

Type.....LED lights

* Maximum total number of passengers assumes one rider accompanied by one standing adult per horse plus the maximum per chariot.

** All rides can be electrically wired to operate on other specified voltage. The final contract is used to calculate the required amount of power.

Specifications are effective as of publication date. Because we strive to improve every Chance Rides product, these specifications are subject to change without notice. Dimensions are approximate. For actual dimensions and installation specifications, please refer to Chance Rides foundation drawings. This ride conforms to all applicable ASTM amusement ride standards in effect on the date of manufacture.

